

TriLane

Tripod turnstile



AS AUTOMATIC
SYSTEMS

Access controlled...
Future secured



TRILANE TRIPOD TURNSTILES ARE DESIGNED FOR DISSUASIVE AND ECONOMICAL ACCESS CONTROL AND ALLOW THE FIXING OF CONTROL EQUIPMENT SUCH AS: PROXIMITY SCANNERS, BAR CODE SCANNERS, BADGE COLLECTORS, ETC.

Their mechanisms, of robust and reliable design, exist in various configurations covering all most likely encountered cases in terms of pedestrian access control.

TriLane turnstiles can be installed indoors or outdoors, alone or in battery. It can be combined with Automatic Systems' AccessLane gate to generate a passageway for people with reduced mobility.

TRILANE SERIES



TL1 Standard



TL1 Stainless steel



TL2 Standard



TL2 Hybrid



TL2 Stainless steel

MAIN BENEFITS

- Bi-directional turnstile made especially for quick access control in areas with high traffic but limited space
- Non-removable stainless steel arms to prevent vandalism
- Durable, corrosion-resistant, heavy-duty mechanism for extended service life

APPLICATIONS

As an access-control application, the TriLane tripod turnstile is a true “tank” that withstands repeated wear and tear in high-volume pedestrian areas in:

- Schools, universities and colleges
- Office buildings, head offices, administrative sites
- Industrial and manufacturing facilities
- Sports centers, cultural or entertainment venues
- Ports and harbours



COMFORTABLE FOR END-USERS

- 510mm arm for wide and comfortable lanes (550mm free passage width)
- Collapsible arms (for easy evacuation in case of power outage / emergency) do not hinder the users passage
- LED pictograms for intuitive use and high throughput in both directions
- Motorization for rearming and/or pre-rotation of the arm for movement assistance with adjustable speed
- Hydraulic shock absorber for a smooth and silent operation (60dB @ 1m)

COMPACT DESIGN

- Superior quality finished housing: painted aluminium, painted steel, stainless steel 304L or 316L; various choice of colours
- Slim and short cabinet(s) for a transparent integration within the architectural landscape

RELIABLE

- Built to withstand intensive operation (single-user throughput up to 20 pers./min)
- Built to withstand abusive use
- Fraud attempt detection (both jump-over and crawl-under)
- Mechanical locking to withstand forced entry attempts (whatever motorized or not)
- Anti-pass back device to avoid unauthorized use by preventing any rotation once the mechanism has moved 60° away from initial position
- Auto-centering mechanism to guarantee a complete rotation
- Non-removable arms (version with the fixed arms)

ROBUST

- Inside / Outside use (IP44 grade) & down to -40°C
- Arm capable of bearing a load of 100 Kg applied in its middle or resisting an impact of 240 Joules applied in the center of the arm
- No visible screws on the turret (version with the fixed arms) and hexagonal screws are used to affix the arm onto the turret (version with the collapsible arm)



WATCH THE VIDEO

LOW TOTAL COST OF OWNERSHIP

- Superior mechanical systems and electronics, providing highly reliable products with MCBF of 5 million cycles
- Low energy consumption ensuring a low carbon footprint (consumption in standby mode < 15 W, in duty cycle < 55 W, at max < 85 W)
- Light product (TL2 60kg, TL1 46kg) to make installation easier and faster with less human resources
- Mean time to repair in less than 30 minutes



UPGRADABLE WITH MULTIPLE INTEGRATIONS

Housing offers 2 free spaces for the integration of added customer functionalities such as proximity readers.



EASY TO MAINTAIN & MONITOR

LAN-connectivity to Building Maintenance Systems, using web-based interfaces or a dedicated software monitoring, enabling the supervision of all operation performances.



ANTI CORROSION TREATMENT

All internal parts are treated by zinc coating and passivation.



**FRAUD
DETECTION**



WORKING MODES

The TriLane turnstile can operate in 5 different modes for each passage direction.

- 1 Access permanently free
- 2 Access permanently mechanically locked
- 3 Access mechanically locked with automatic unlocking device to allow free passage in case of power failure (free rotation)
- 4 Electrically controlled access
- 5 Access electrically controlled with automatic unlocking device to give free passage in case of power failure (free rotation)

OPTIONAL

- Collapsible arm
- Long arm (550mm) (TL1 only)
- Motorization with movement assistance and with rearming of the collapsible arm
- Bidirectional passage
- Function pictogram
- Kit for reader integration Fraud attempt detection with TOF camera
- AISI 304L stainless steel end boxes (2 directions)
- Full AISI 304L stainless steel housing
- Full AISI 316L stainless steel housing
- Door for stainless steel end box With or without collection box
- Network connectivity (IP)
- Paint in: RAL6014, RAL7003, RAL7016, RAL9010
- Thermostated heating (for operation until -20°C)
- Thermostated heating (for operation until -40°C)
- Push button (free exit)

STANDARD TECHNICAL SPECIFICATIONS

	TL1	TL2
Net weight	46kg	60kg
Passage (width)	550 mm	
Power supply	100 - 230V single phase, 50/60 Hz	
Consumption	Standby mode: < 15 W Duty cycle: < 55 W Maximum: < 85 W	
Ambient operating temperature	from -10° to + 50° C	
Flow	Up to 20 passages/minute	
MCBF (Mean Cycles Between Failures) when respecting recommended maintenance	5.000.000	
IP	44	
Certifications	Conform to European standards CE ISO 9001-2015	

STANDARD DIMENSIONS (MM)

TL1

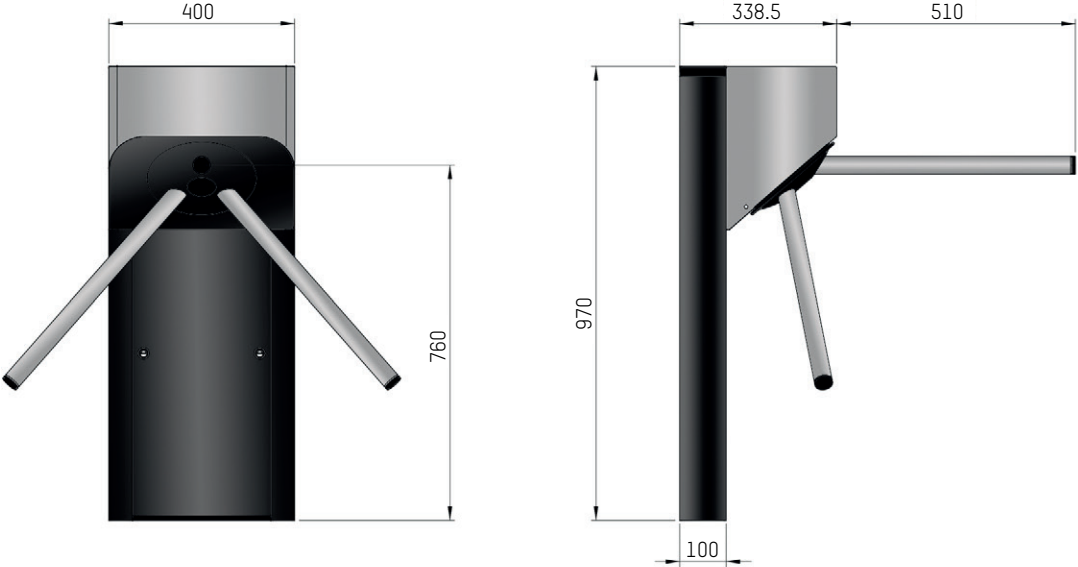

TL2

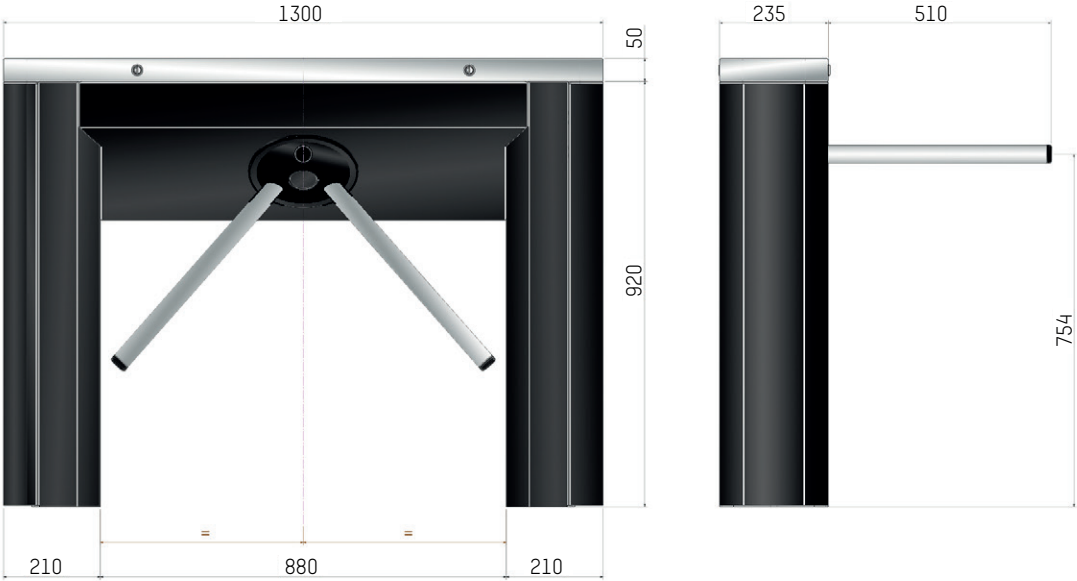



Access controlled...
Future secured

HEADQUARTERS - INTERNATIONAL SALES AUTOMATIC SYSTEMS SA

Avenue Mercator 5 – 1300 Wavre
BELGIUM

T.: +32 (0)10 230 211
sales.asgroup@automatic-systems.com
www.automatic-systems.com

LOCAL OFFICES IN THE WORLD

FRANCE

T.: +33 (0)1 30 28 95 50 (Persan office)
T.: +33 (0)1 56 70 07 07 (Suresnes office)
Email: sales.fr@automatic-systems.com

SPAIN

T.: +34 (0)93 478 77 55 (Barcelona office)
T.: +34 (0)91 659 07 66 (Madrid office)
Email: sales.es@automatic-systems.com

UNITED KINGDOM

T.: +44 (0)1604 65 42 10
Email: sales.uk@automatic-systems.com

UNITED STATES

T.: +1 516 944 94 98
Email: sales.us@automatic-systems.com

CANADA

T.: +1 450 659 07 37
Email: sales.ca@automatic-systems.com

DISCOVER ADDITIONAL CONTENT IN AUGMENTED REALITY.

